

## Operation

### Operation

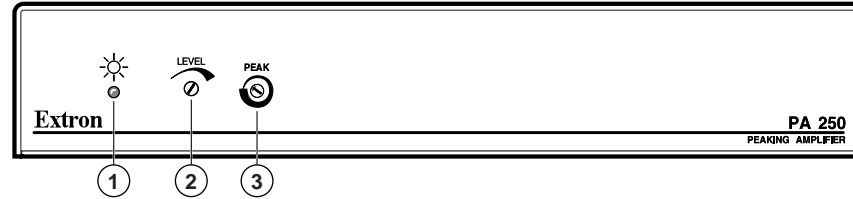

Figure 4 — PA 250 front panel

- ① **Power LED** — Lights when the PA 250 is on.
- ② **Level control** — Adjusts the amount of compensation for amplitude losses caused by cable resistance.
- ③ **Peaking control** — Adjusts frequency compensation. It is similar to the sharpness control on a television. It compensates for the effect of capacitance of long cables. Use the symbol at the left as a guide for adjusting the control.



## Specifications

### Video

Gain adjustment .....	-4.9dB to 3.0dB
Peaking adjustment .....	30 MHz to 100 MHz, maximum +8dB
Bandwidth .....	250 MHz (-3dB)

### Video input

Number/signal type .....	1 analog RGBHV, RGBS, RGsB, RsGsBs
Connectors .....	5 BNC female
Nominal level(s) .....	Analog ..... 0.7V p-p
Minimum/maximum level(s) ...	Analog ..... 0.4V to 2.0V p-p with no offset
Impedance .....	75 ohms
Horizontal frequency .....	15 kHz to 150 kHz
Vertical frequency .....	40 Hz to 140 Hz
Return loss .....	-37dB @ 5 MHz

### Video output

Number/signal type .....	1 analog RGBHV, RGBS, RGsB
Connectors .....	5 BNC female
Nominal level .....	Analog ..... 0.4V to 2.0V p-p
Impedance .....	75 ohms
Return loss .....	-20dB @ 5 MHz

## Specifications

DC offset ..... ±10mV maximum

### Sync

Input type .....	RGBHV, RGBS, RGsB, RsGsBs
Output type .....	RGBHV, RGBS, RGsB
Input level .....	RGBHV, RGBS ..... TTL ..... 5V p-p RGsB, RsGsBs ..... analog ..... 0.3V p-p
Output level .....	TTL ..... 4V to 5V p-p
Input impedance .....	510 ohms
Output impedance .....	75 ohms
Max input voltage .....	5V p-p
Input sensitivity .....	0.6V to 5V p-p
Max. propagation delay .....	130 nS
Max. rise/fall time .....	4 nS
Polarity .....	RGBHV, RGBS ..... positive or negative (follows input) RGsB, RsGsBs ..... negative

### General

Power .....	100VAC to 240VAC, 50/60 Hz, 10 watts, internal, auto-switchable
Temperature/humidity .....	Storage -40° to +158°F (-40° to +70°C) / 10% to 90%, non-condensing Operating +32° to +122°F (0° to +50°C) / 10% to 90%, non-condensing
Rack mount .....	Yes, with optional rack shelf #60-190-01
Enclosure type .....	Metal
Enclosure dimensions .....	1.75" H x 8.75" W x 9.5" D 4.45 cm H x 22.23 cm W x 24.13 cm D
Shipping weight .....	5 lbs (2.3 kg)
Vibration .....	NSTA 1A in carton (National Safe Transit Association)
Approvals .....	UL, CUL, CE
MTBF .....	30,000 hours
Part number .....	60-179-01
Warranty .....	2 years parts and labor

### Part number

Part number ..... 60-179-01

**NOTE** Specifications are subject to change without notice.



Extron Electronics, USA  
1230 South Lewis Street, Anaheim, CA 92805  
800.633.9876 714.491.1500 FAX 714.491.1517  
USA

Extron Electronics, Europe  
Beeldschermweg 6C, 3821 AH Amersfoort  
+31.33.453.4040 FAX +31.33.453.4050  
The Netherlands

Extron Electronics, Asia  
135, Joo Seng Rd. #04-01, PM Industrial Bldg.  
+65.383.4400 FAX +65.383.4664  
Singapore 368363

Extron Electronics Information  
ExtronWEB™: www.extron.com  
ExtronFAX™: 714.491.0192  
24-hour access—worldwide!

© 2000 Extron Electronics. All rights reserved.

**Extron® Electronics**  
INTERFACING, SWITCHING AND DISTRIBUTION



## User's Guide



**PA 250**  
**Peaking Amplifier**

68-202-02 A  
Printed in the USA  
01 01

## Introduction

The Extron PA 250 is a long-line peaking amplifier for driving RGB video up to 1,000 feet. It can also be used as a sync stabilizer to eliminate jitter. Other features include:

- RGB video bandwidth of 250 MHz
- Sync combining, boost, and sharpness capabilities
- Automatically strips incoming sync from the red, green, and blue channels.

**NOTE** The quality of the image depends on the quality of all of the components in your video system, including the cables.

## Rear Panel Connectors and Controls

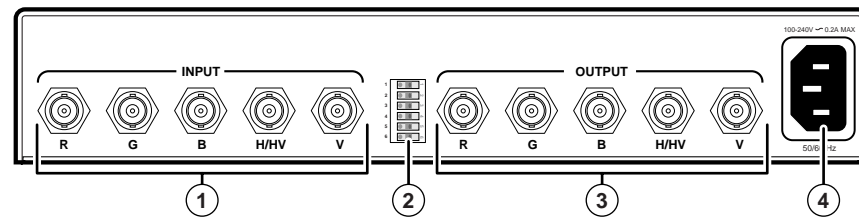

Figure 1 — PA 250 rear panel

- 1 **Input BNC connectors** — Attach to the input device.
- 2 **DIP switches** — The default for all switches is Off. If switches 1, 2, and 6 are Off, sync output depends on the impedance of the output cables (75 ohm on RGB cables, up to 1 kohm on sync lines).
  - 1 — **SOG defeat**
    - On — Sync on green (SOG) is not allowed. This setting prevents the PA 250 from outputting an RGsB signal.
    - Off — Automatic sync detection is used (default setting).
  - 2 — **Force H&V**
    - On — H and V sync are always separated. This setting prevents the PA 250 from outputting an RGBS signal.
    - Off — Automatic sync detection is used (default setting).
  - 3 — **Force negative sync**
    - On — Sync pulses are always negative.
    - Off — Sync output polarity follows input polarity.
  - 4 — **Serration pulse removal**
    - On — Serration pulse are removed from the output vertical sync pulse. LCDs, DLPs and plasma displays must have the serration pulses removed to display properly.

## Installation

**NOTE** Flagging or bending at the top of the video image is a sign that the serration pulses should be removed.

Off — Serration pulses pass through the PA 250.

### 5 — Pulse width

On — Vertical sync pulse width = 500  $\mu$ seconds.

Off — Vertical sync pulse width = 150  $\mu$ seconds.

### 6 — Digital display sync processing™ (DDSP™)

On — LCD (digital display) sync processing is on.

Off — Normal sync processing is active.

3 **Output BNC connectors** — Attach to the output device.

4 **AC power input connector** — Attach a standard IEC power cord (100VAC to 240VAC, 50/60 Hz).

## Installation Overview

- 1 Turn all of the equipment off. Ensure that the source device, the PA 250, and the output device are turned off and disconnected from the power source.
- 2 If desired, mount the PA 250 in a rack. See “Mounting the PA 250” below.
- 3 Cable the inputs and outputs to the PA 250. See “Cabling” on page 3.
- 4 Set the rear panel DIP switches. See (2) on page 1.
- 5 Plug the input device, the PA 250, and the output device into a grounded AC source.
- 6 Turn on the input and output devices.

## Mounting the PA 250

If desired, mount the PA 250 to a rack shelf (Extron part number 60-190-01) as follows:

1. If feet were installed on the bottom of the PA 250, remove them.
2. Mount the PA 250 on the rack shelf, using two 4-40 x 1/8 screws in opposite (diagonal) corners to secure the case to the shelf.
3. Attach the false front panel (provided with the rack shelf) to the unoccupied side of the rack, or install a second half-rack device.
4. Attach the rack shelf to the rack using four 10-32 x 3/4” bolts (provided). Insert the bolts through the #10 beveled washers, then through the holes in the rack ears and rack.

## Installation, cont’d

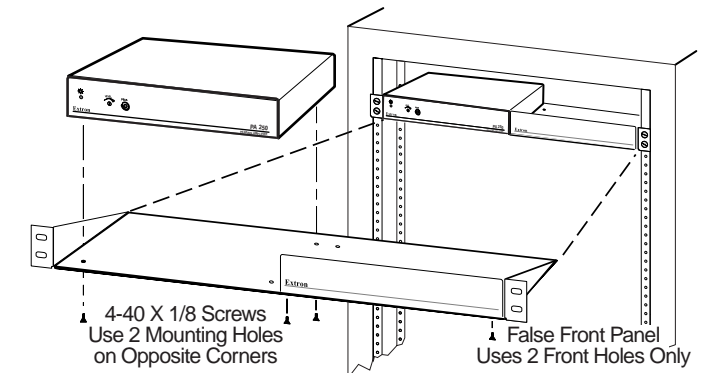

Figure 2 — Rack mounting the PA 250

## Cabling

Connect input and output cables to the PA 250 as shown below.



The PA 250 can be attached to an input device, such as an interface connected to a personal computer, and to an output device, such as a large screen projector. The following figure shows a typical application.

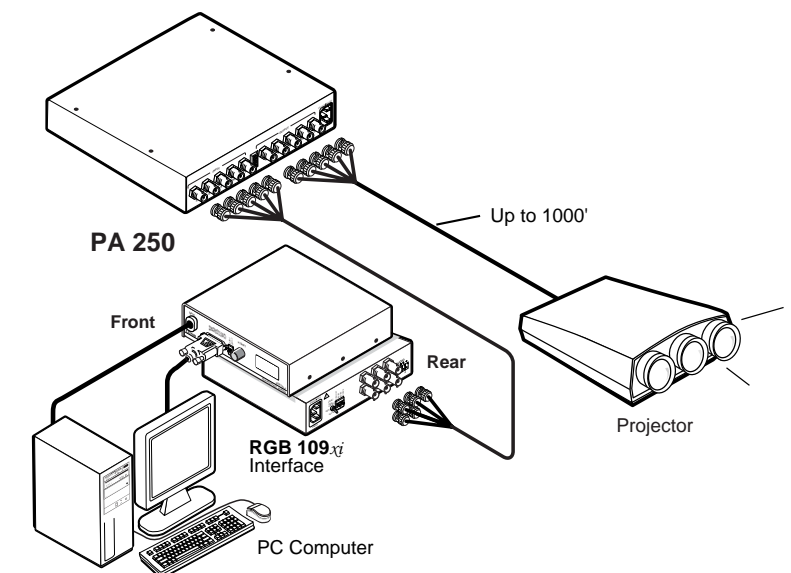

Figure 3 — Typical PA 250 application